

S S a a a a a

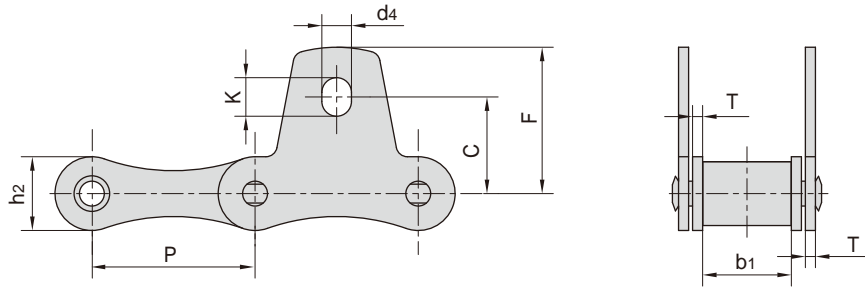

东华链号 Donghua Chain No.	P	b ₁	h ₂	T	C	F	d ₄	K
	mm	mm	mm	mm	mm	mm	mm	mm
S32SK1	29.21	15.88	13.2	1.8	17.3	26.20	5.3	6.9
S42SK1	34.93	19.05	19.8	2.8	23.6	34.30	8.3	11.5
S42SK1F1	34.93	19.05	19.8	2.8	22.9	33.33	8.3	11.5
S45SK1	41.40	22.23	17.3	2.8	19.8	30.20	8.3	11.5
S52SK1	38.10	22.23	17.3	2.8	22.1	31.80	8.3	9.9
S55SK1	41.40	22.23	17.3	2.8	19.8	30.20	8.3	11.5
S62SK1	41.91	26.20	17.3	2.5	24.6	38.60	8.3	14.7
S77SK1	58.34	22.23	26.2	4.0	36.3	50.00	8.3	11.5
S88SK1	66.27	28.58	26.2	4.0	43.7	55.60	8.3	9.9
S32SK1F1	29.21	15.88	13.2	1.8	16.7	25.68	6.5	8.1
S55RHSK1	41.40	22.23	22.4	4.0	19.8	30.20	8.3	11.5

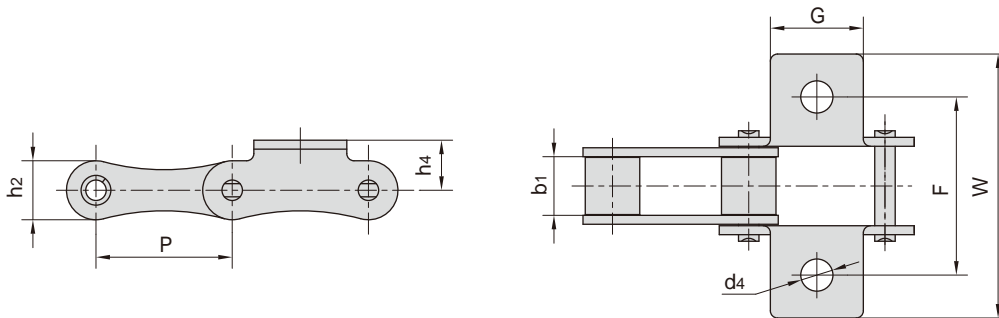

东华链号 Donghua Chain No.	P	b ₁	G	F	W	h ₄	d ₄	h ₂
	mm	mm	mm	mm	mm	mm	mm	mm
S52LK1	38.10	16.40	26.0	50.0	74.0	14.0	9.0	16.5
55VK1	41.40	22.23	30.0	58.0	76.0	16.0	9.0	20.0
S42F2K1F1	34.93	19.05	45.0	54.8	75.2	14.0	8.3	19.8
S52LF1K1	38.10	16.00	26.0	50.0	74.0	16.0	9.0	16.5
55VDK1	41.40	23.00	30.0	58.0	76.0	16.0	9.0	20.0

