

Conveyor chains for road construction machinery

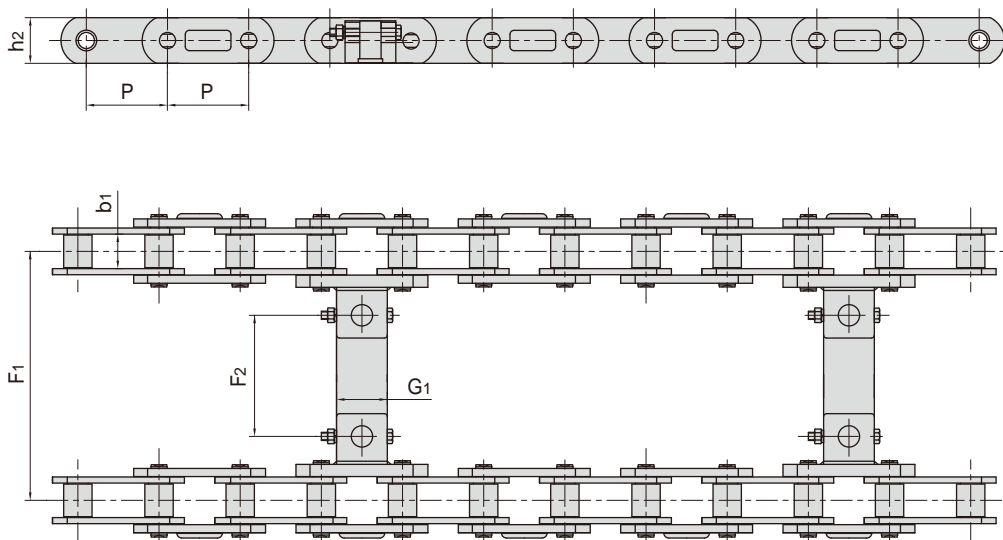

东华链号 Donghua Chain No.	P	b1	h2	F1	F2	G1
	mm	mm	mm	mm	mm	mm
P80F8	80.0	33.8	45.0	575.0	449.0	50.0
P80F17	80.0	35.3	45.0	575.0	442.4	50.0
P80F27	80.0	35.3	46.0	497.4	385.0	50.0
P80F41	80.0	33.8	45.0	509.5	396.5	50.0
P80F45	80.0	35.0	45.0	540.0	425.0	50.0
TPJP80F1	80.0	33.8	45.0	500.0	374.0	50.0
TPJP80F3	80.0	33.8	45.0	561.0	448.0	50.0
TPJP80F4	80.0	33.8	45.0	585.0	472.0	50.0
TPJP80F12	80.0	33.8	45.0	584.5	471.5	50.0



Conveyor chains for road construction machinery

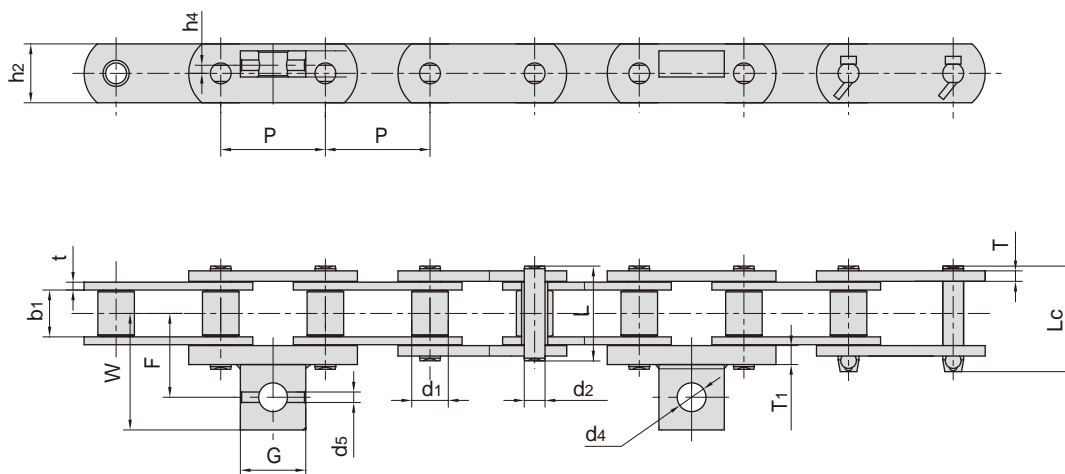

东华链号 Donghua Chain No.	F	W	G	h_4	d_4	d_5	T_1
	mm	mm	mm	mm	mm	mm	mm
P70F23	43.75	64.1	40.0	6.5	22.0	7.0	5.00
M112F12-S-70	60.00	77.4	30.0	7.5	15.0	-	10.00
P75	32.20	46.2	30.0	5.2	14.0	-	4.00
P78.11F29	53.10	78.5	50.8	12.7	19.3	-	7.95
P80F7	56.40	81.4	50.5	5.0	21.0	8.2	6.20
P80F8	63.00	88.0	50.0	8.0	22.0	10.2	14.20
P80F17	66.30	91.3	50.0	-	24.0	-	15.00
P80F19	56.50	81.5	50.0	6.2	22.0	8.0	8.00
P80F21	57.00	82.0	50.0	-	21.5	-	8.00
P80F27	56.20	81.5	50.5	-	21.0	-	6.20
P80F29	56.50	81.5	50.0	6.2	22.0	10.0	8.00
P80F30	57.00	82.2	50.5	5.0	21.0	-	8.00
P80F39	56.50	81.5	50.0	6.2	22.0	8.0	8.00
P80F45	57.50	80.0	50.0	-	25.0	-	8.00
P80F51A1	57.00	82.0	50.0	-	20.5	-	8.00
P80F62	56.50	81.5	50.0	6.5	22.0	8.6	8.00
P80F69	56.50	82.2	50.5	5.5	20.5	-	8.00
P80F87	58.50	72.4	48.0	-	12.0	-	10.00



