

A-2

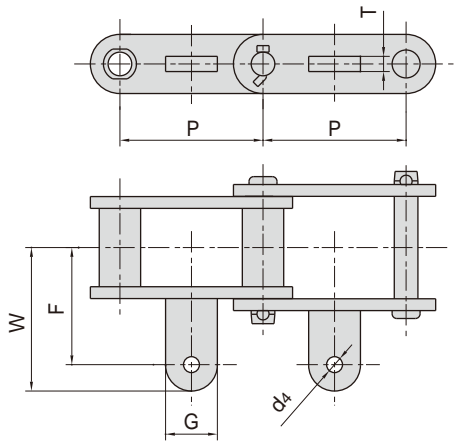

Engineering steel bush chain attachments

A-22



ANSI 链号 ANSI Chain No.	东华链号 Donghua Chain No.	P	G	F	W	d4	T
		mm	mm	mm	mm	mm	mm
S188		66.27	49.2	45.2	61.2	10.2	10.4
	S188A22F1	66.27	32.0	45.2	61.2	12.0	6.4

ANSI 链号 ANSI Chain No.	P	G	L	F1	F2	W	h4	d4	T
	mm	mm	mm	mm	mm	mm	mm	mm	mm
S150	153.67	109.5	69.9	190.5	292.1	347.5	47.8	13.5	13.5
S856	152.40	152.4	69.9	166.6	277.9	349.3	47.8	13.5	13.5

K-3

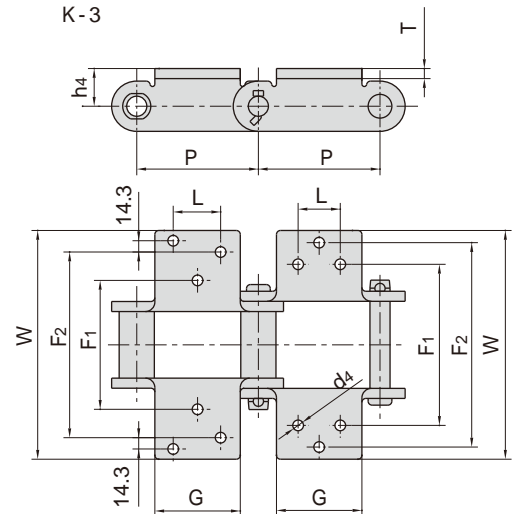

K-35

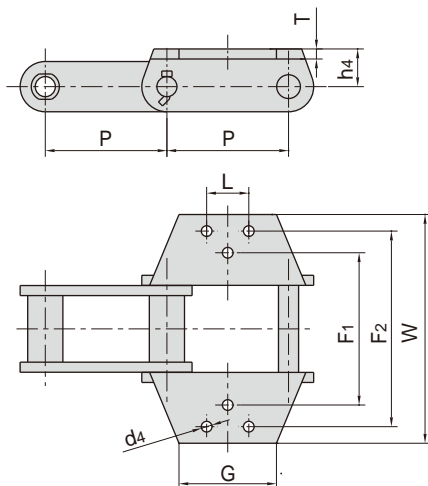

ANSI 链号 ANSI Chain No.	P	G	L	F1	F2	W	h4	d4	T
	mm	mm	mm	mm	mm	mm	mm	mm	mm
S856	152.4	90.00	63.50	184.2	298.50	349.30	47.8	16.80	13.50
S102BF3K2	101.6	101.00	44.50	-	132.00	164.00	38.1	11.00	10.00
S111F2K2	120.9	120.65	58.67	-	158.74	195.33	38.1	14.23	9.65
S856F8K3	152.4	90.00	64.00	199.5	314.00	355.00	71.0	17.00	16.00

K-35

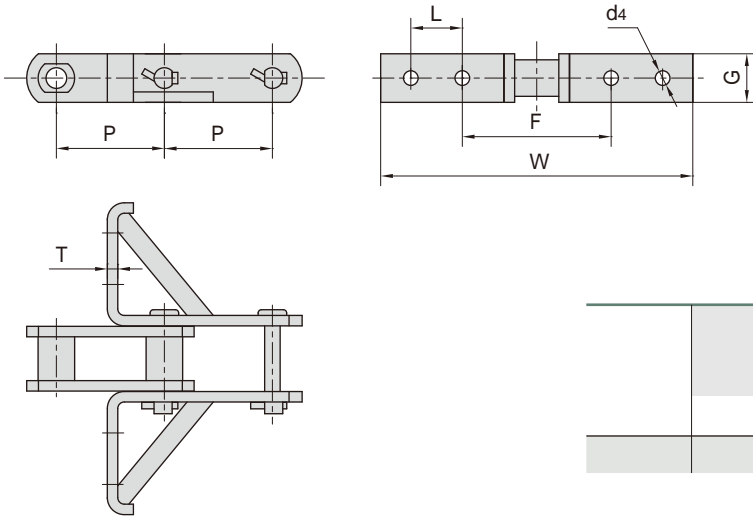

ANSI 链号 ANSI Chain No.	P	G	L ₁	L ₂	F ₁	F ₂	W	h ₄	d ₄	T
	mm	mm	mm	mm	mm	mm	mm	mm	mm	mm
S857	152.4	146.1	88.9	88.9	177.8	304.8	355.6	63.5	13.5	13.5
S859	152.4	146.1	114.3	69.9	228.6	330.2	381.0	76.2	16.8	13.5
S864	177.8	146.1	139.7	95.3	228.6	330.2	381.0	76.2	16.8	13.5

K-44

