

Tobacco conveyer chains

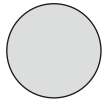
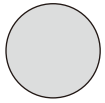

东华链号
Donghua
Chain No.

Pin mm
链板高度max
Pin
销轴长度max

抗拉强度
Tensile
Strength

东华链号
Donghua
Chain No.

d2 max
销轴直径
Pin
diameter

7.1

节距
Pitch
P

d1 mm
滚子直径
Roller
diameter
Width
between
inner plates

29225 143.0

mm
b1 内节内宽
min

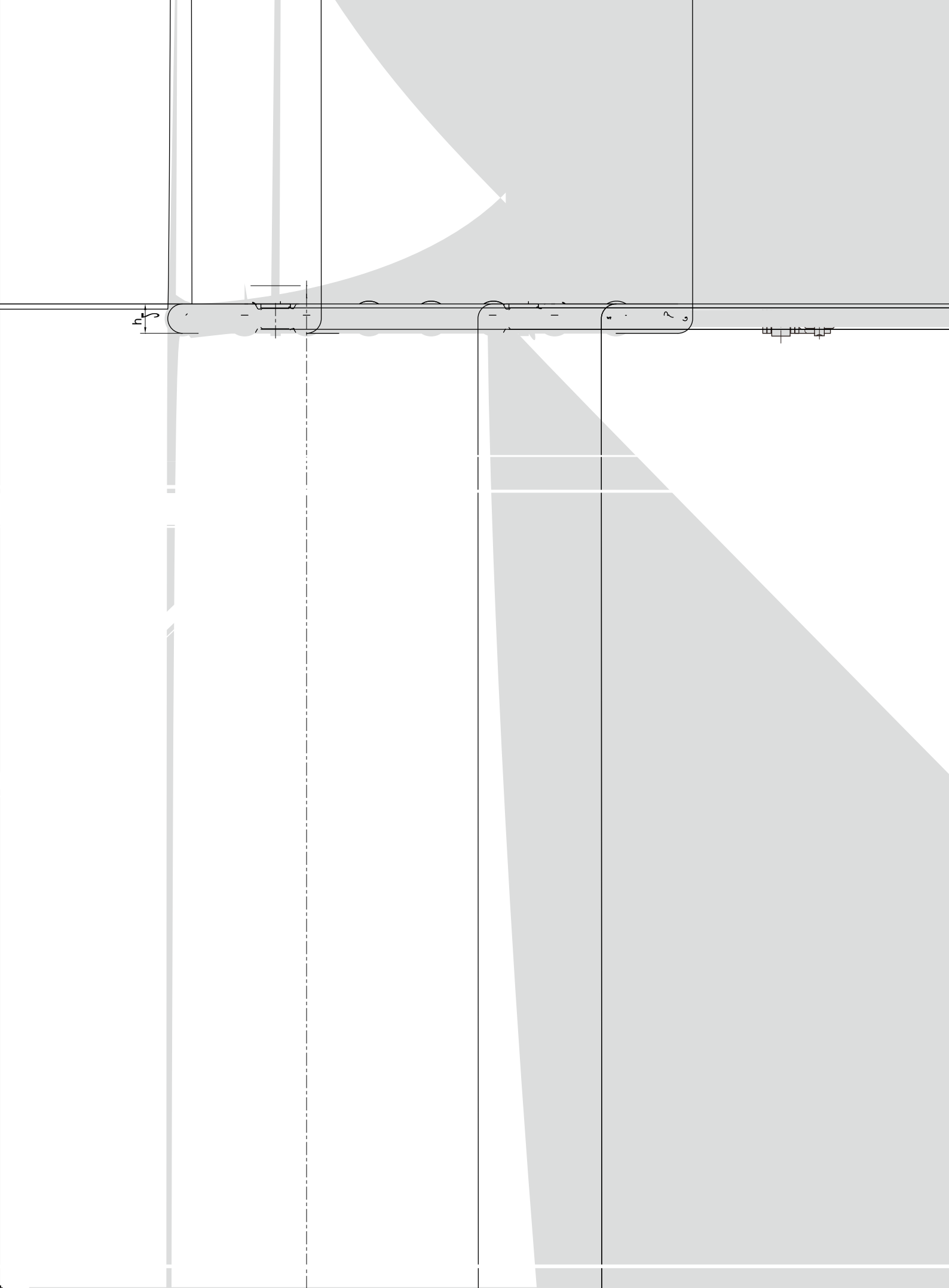

Tobacco conveyor chains

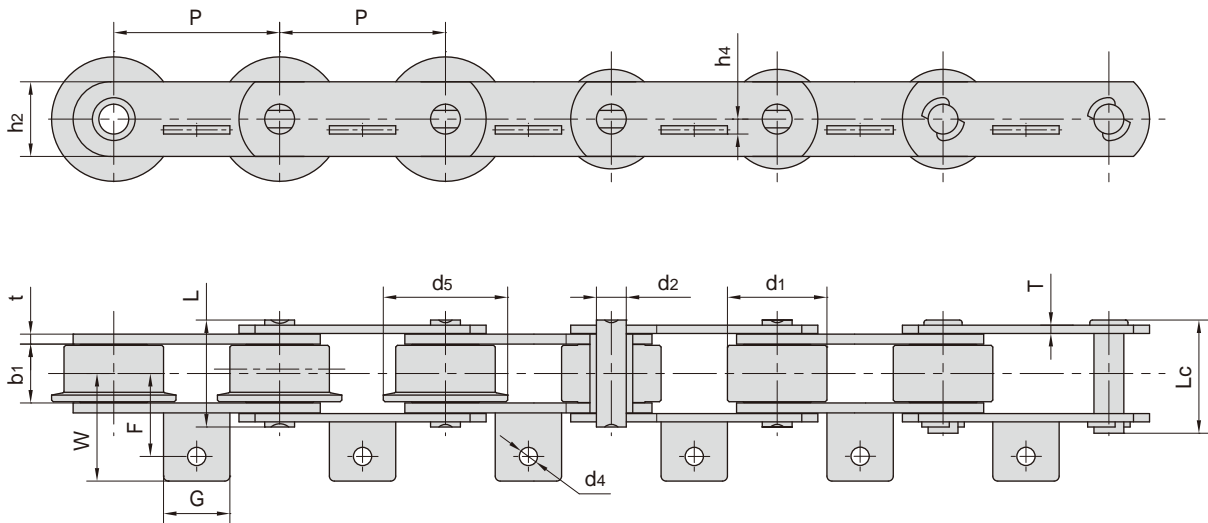

东华链号 Donghua Chain No.	G	F	W	h4	d4
	mm	mm	mm	mm	mm
P100F74	40.0	55.00	73.0	8.0	12.0
P100F171	40.0	55.00	73.5	10.0	12.0
P100F173A1	40.0	47.25	64.3	9.5	11.0
P100F260A1	40.0	55.00	73.0	8.0	12.0
P160F104A1	50.0	64.00	99.0	15.0	13.0

东华链号 Donghua Chain No.	节距 Pitch	滚子直径 Roller diameter		内节内宽 Width between inner plates	销轴直径 Pin diameter	销轴长度 Pin length		链板高度 Plate depth	链板厚度 Plate thickness	抗拉强度 Tensile strength	平均抗拉强度 Average tensile strength	每米长重 Weight per meter
	P	d1 max	d5 max	b1 min	d2 max	L max	Lc max	h2 max	t/T max	Q min	Q0	q
	mm	mm	mm	mm	mm	mm	mm	mm	mm	kN/lbf	kN	kg/m
P100F74	100.0	60.0	-	34.0	18.0	-	69.0	45.0	6.0/5.0	140/31470	150.0	13.80
P100F171	100.0	60.0	-	35.0	18.0	65.0	69.5	41.0	6.0/5.0	140/31470	150.0	13.17
P100F173A1	100.0	60.0	75.0	36.0	18.0	65.0	70.5	45.0	6.0/5.0	140/31470	150.0	16.10
P100F260A1	100.0	60.0	-	34.0	18.0	-	63.0	45.0	4.0	120/26977	130.0	11.20
P160F104A1	160.0	80.0	96.0	48.0	25.0	95.5	102.0	65.0	10.0/8.0	315/70812	330.7	28.30

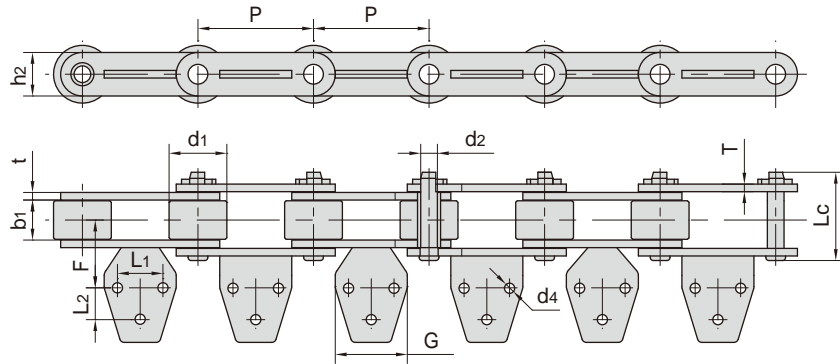

东华链号 Donghua Chain No.	G	F	L1	L2	d4
	mm	mm	mm	mm	mm
P76.2F63A3	47.5	44.7	30.0	21.0	6.7

东华链号 Donghua Chain No.	节距 Pitch	滚子直径 Roller diameter	内节内宽 Width between inner plates	销轴尺寸 Pin dimension		链板高度 Plate depth	链板厚度 Plate thickness		平均抗拉强度 Average tensile strength	每米长重 Weight per meter
	P	d1 max	b1 min	d2 max	Lc max	h2 max	t/T max	Q min	Q0	q
	mm	mm	mm	mm	mm	mm	mm	kN/lbf	kN	kg/m
P76.2F63A3	76.2	38.1	25.2	11.0	57.0	28.7	5.0	80/17984	88.0	7.10

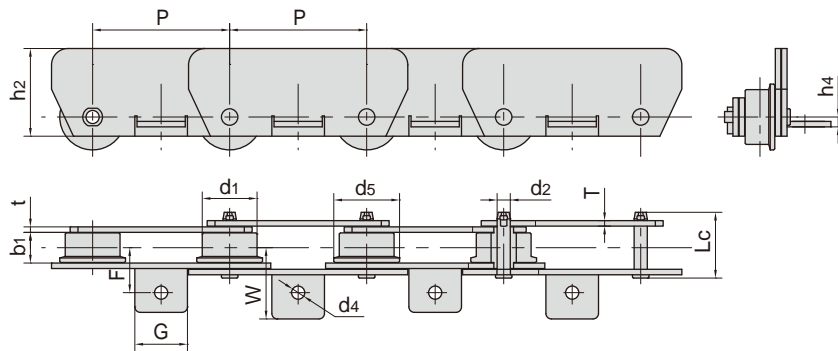

东华链号 Donghua Chain No.	G	F	W	h4	d4
	mm	mm	mm	mm	mm

东华链号 Donghua Chain No.	节距 Pitch	滚子直径 Roller diameter		内节内宽 Width between inner plates	销轴尺寸 Pin dimension		链板高度 Plate depth	链板厚度 Plate thickness		平均抗拉强度 Average tensile strength	每米长重 Weight per meter
	P	d1 max	d5 max	b1 min	d2 max	Lc max	h2 max	t/T max	Q min	Q0	q
	mm	mm	mm	mm	mm	mm	mm	mm	kN/lbf	kN	kg/m
M80F36A1-F-125	125.0	50.0	60.0	28.0kg	28.0ReeSS	c64	W5	3d	"	28.0	

