

东华链号 Donghua Chain No.	节距 Pitch	滚子直径 Roller diameter	内节内宽 Width between inner plates	销轴尺寸 Pin dimension		链板尺寸 Plate dimension					链板厚度 Plate thickness	抗拉强度 Tensile strength	平均抗拉强度 Average tensile strength	每米长重 Weight per meter
	P	d1 max	b1 min	d2 max	L max	h2 max	d3 max	d4 max	J max	K max	T max	Q min	Q ₀	q
	mm	mm	mm	mm	mm	mm	mm	mm	mm	mm	mm	kN/lbf	kN	kg/m
3939-B4	203.2	23.0	27.0	11.1	49.0	28.58	7.2	7.2	38.1	101.6	4.0	115.58/26268	136.5	2.45
3939-B21	203.2	23.0	27.0	11.1	49.0	28.58	7.2	-	38.1	-	4.0	115.58/26268	136.5	2.45
3939-B23	203.2	23.0	27.0	11.1	49.0	28.58	-	10.3	-	92.1	4.0	115.58/26268	136.5	2.45
3939-B24	203.2	23.0	27.0	11.1	49.0	28.58	-	7.2	-	101.6	4.0	115.58/26268	136.5	2.48
3939-B40	203.2	23.0	27.0	11.1	49.0	28.58	-	10.3	-	101.6	4.0	115.58/26268	136.5	2.45
3939-B43	203.2	23.0	27.0	11.1	49.0	28.58	7.2	10.3	38.1	92.1	4.0	115.58/26268	136.5	2.42
3939-B44	203.2	23.0	27.0	11.1	49.0	28.58	7.2	10.3	38.1	101.6	4.0	115.58/26268	136.5	2.45
3939H-B4	203.2	23.0	27.0	11.1	58.0	28.60	-	7.2	38.0	102.0	6.4	150.00/34082	172.5	3.51

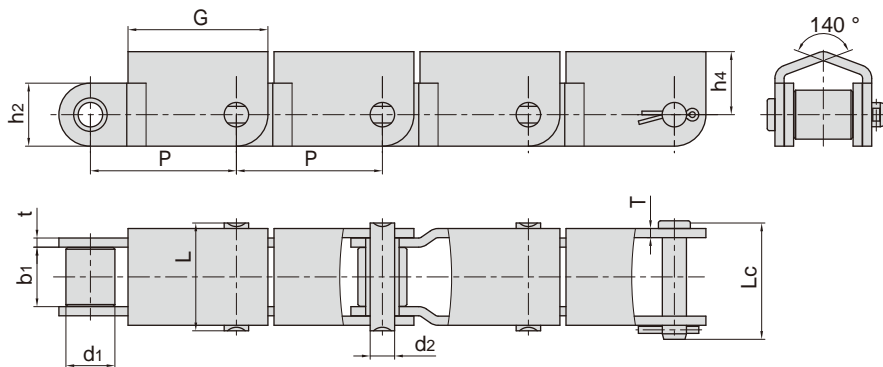

东华链号 Donghua Chain No.	节距 Pitch	滚子直径 Roller diameter	内节内宽 Width between inner plates	销轴直径 Pin diameter	销轴长度 Pin length		链板尺寸 Plate dimension				抗拉强度 Tensile strength	每米长重 Weight per meter
	P	d1 max	b1 min	d2 max	L max	Lc max	h2 max	t/T max	G	h4	Q min	q
	mm	mm	mm	mm	mm	mm	mm	mm	mm	mm	kN/lbf	kg/m
P66.27F6	66.27	22.23	27.00	11.10	49.00	53.80	28.60	4.15	63.50	28.60	97.8/21985	5.25